

action® pro MP

Installation Guide

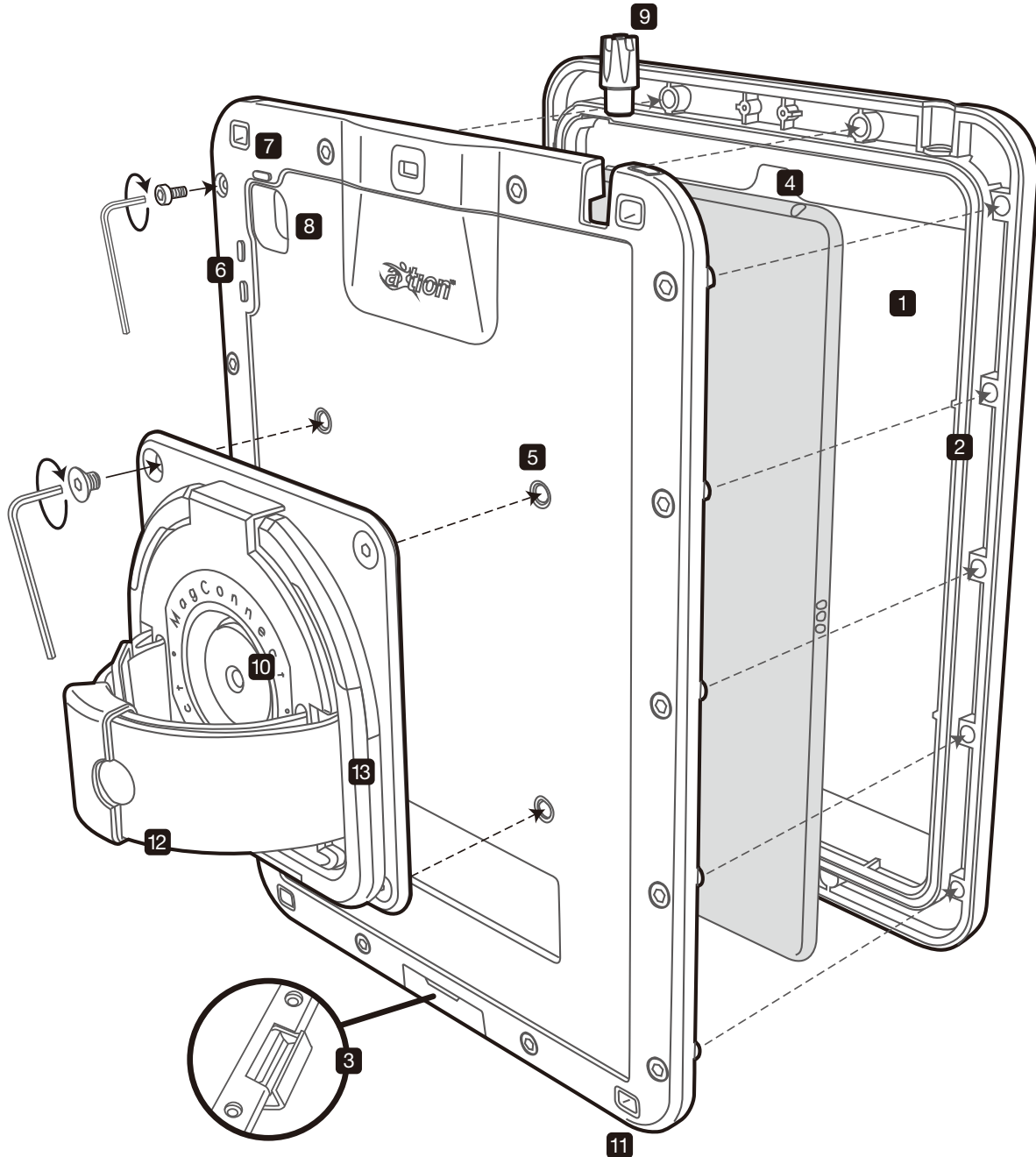

- 1 Screen Protector
- 2 Waterproof Seal
- 3 Charging Port Cover (Water resistant seal when charging)
- 4 Ambient Light Sensor Opening
- 5 VESA 100 Port
- 6 Volume Button
- 7 Power Button

- 8 Camera Opening
- 9 Audio Port Plug
- 10 MagConnect Port (1/4"-20)
- 11 Optional Shoulder Strap Support
- 12 Rotating Hand Strap
- 13 Rotating Kick Stand

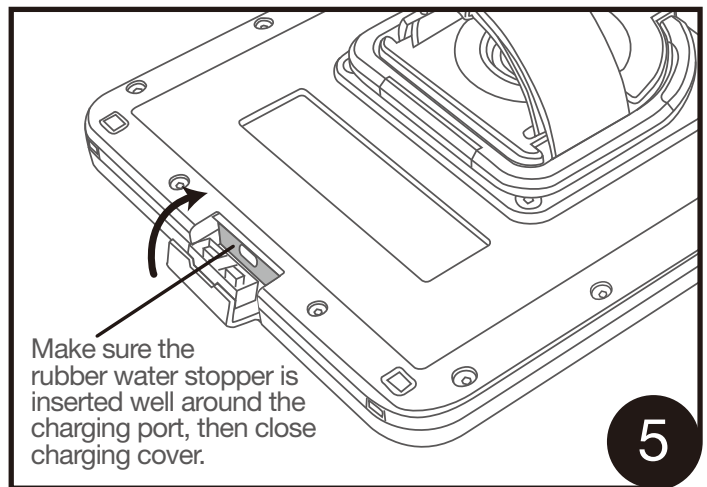
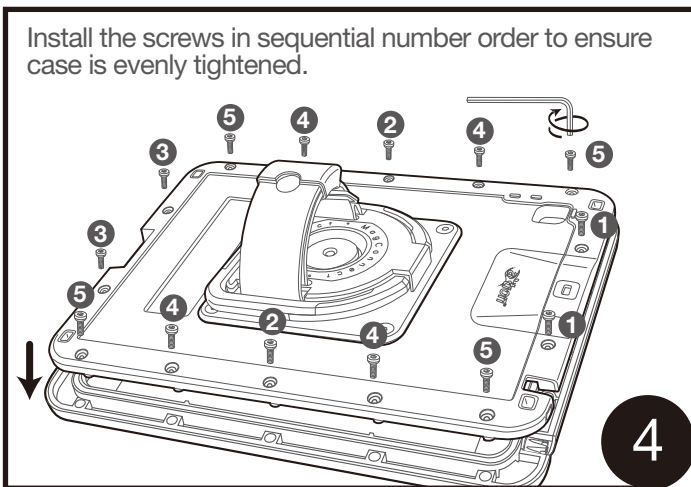
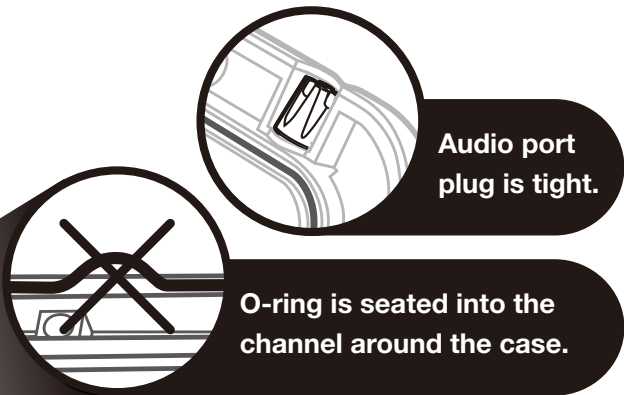
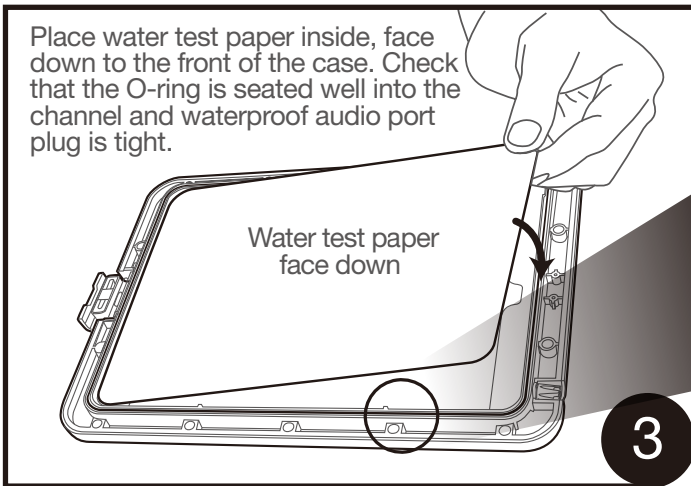
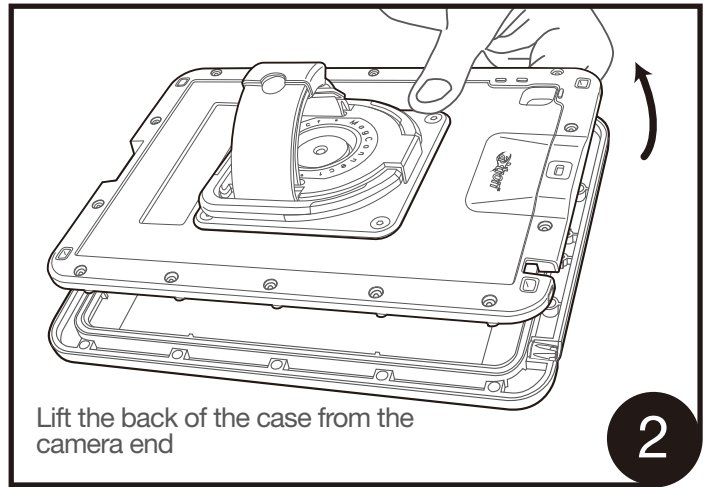
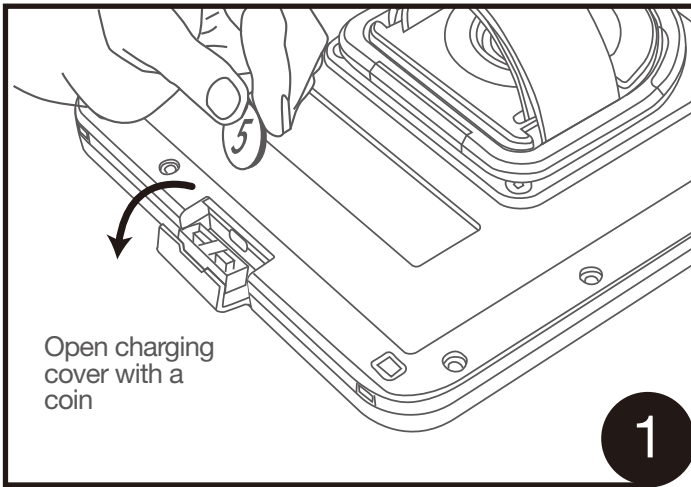

Repeat Steps 4-5

Test under 12" of water for 10 minutes

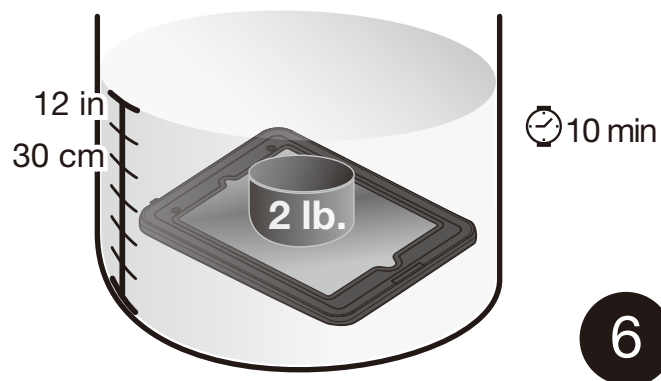

Dry the outer case prior to opening and ensure the water test paper is dry.

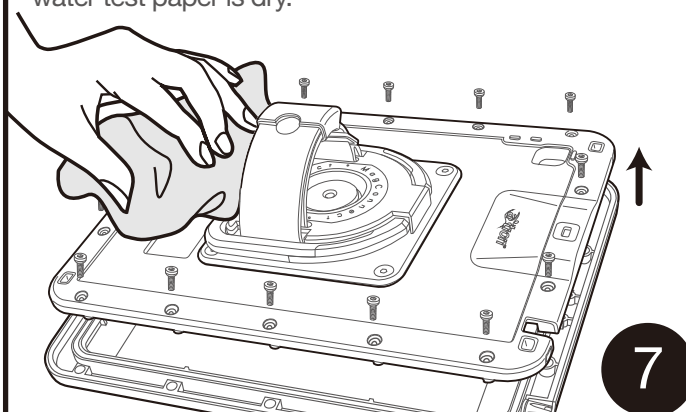

Inspect the water test paper using the instructions printed onto it.

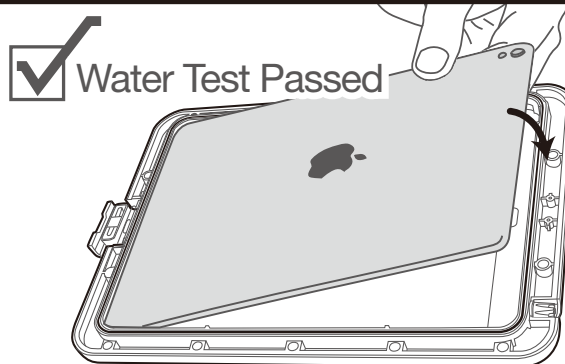
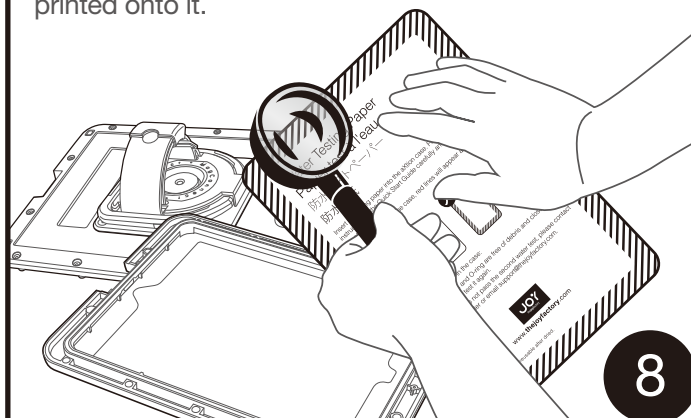

Install the iPad into the front of the case, ensuring proper alignment. Repeat steps 4 - 5.

Repeat Steps 4-5

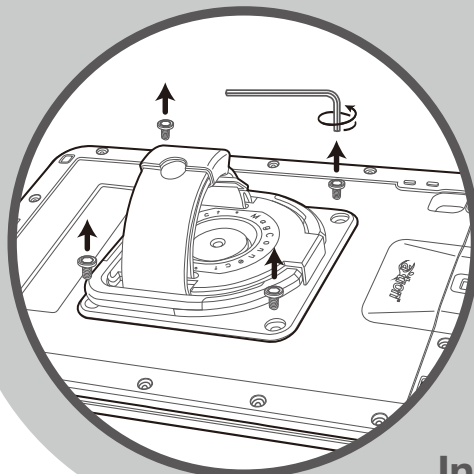

VESA
Installation

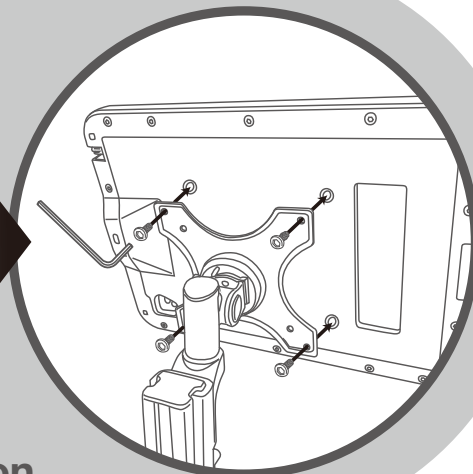



Cleaning Instructions

We recommend cleaning the case after every use cycle. Most hospital-grade disinfectant wipes with high alcohol concentrate are safe to use on the aXtion Pro case. A few that we recommend are:

- Sani-Cloth AF3
- Cavi-Wipes
- Clorox Healthcare Bleach Germicidal Wipes

Follow these steps:

1. Clean the back cover with a hospital-grade wipe, using a small stroking motion. Pay special attention to the crevices.
2. Use a new hospital-grade wipe to clean the front cover and screen protector.
3. Let the case air dry before using.

Internal cleaning may be done as needed following these steps.

1. Remove the tablet from the case and set aside.
2. Clean the inside back cover with a hospital-grade wipe, using a small stroking motion. Pay special attention to the crevices.
3. Use a new hospital-grade wipe to clean the inside front cover and screen protector.
4. Let the case air dry before putting the tablet into the case.

* Hospital-grade disinfectant wipes may have more detailed instructions for use. Please refer to the manufacturer's instructions.

* These instructions are **only** for cleaning cases by The Joy Factory. To clean the tablet, please refer to the manufacturer's instructions.

Accessories

for

aXtion[®] pro MP

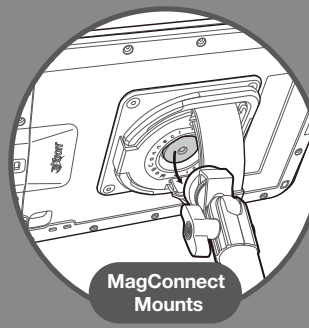

MagConnect Mounts

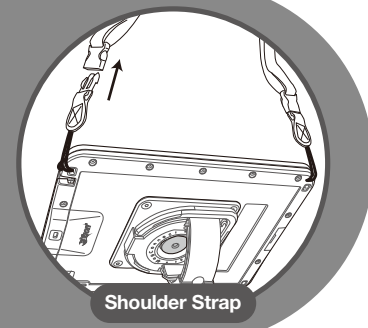

Shoulder Strap

DISCLAIMER FOR aXtion[®] Pro Military Grade and Waterproof Certified Cases

Congratulations on the purchase of your new aXtion Pro case from The Joy Factory Inc!

BEFORE USE READ ALL INSTRUCTIONS CAREFULLY. IMPROPER USE OF THE CASE COULD RESULT IN DAMAGE TO YOUR DEVICE.

This aXtion Pro case is designed only for the device type listed on the box. Thus it is only intended for and only warranted for proper use with that specific tablet and not for use with another device type. Because different generations of tablets have different specifications, please refer to the packaging for your aXtion Pro case to determine whether your tablet will be compatible with the aXtion Pro case you have purchased.

If you are not certain whether the device you intend to use with the aXtion Pro case is compatible with the tablet model you have, please contact the company from which you purchased the device or the manufacturer of the device to determine whether it is a model supported by this aXtion Pro case.

All aXtion Pro cases are certified IP68 waterproof. If you have any questions about whether your case will protect against water in certain situations, contact The Joy Factory prior to using the case in those situations. The IP68 rating means that the aXtion Pro case is certified as "dust tight" (that is, no dust will enter the case when it is properly installed and used). All aXtion Pro cases are also designed to be shock resistant. That is, these cases are designed to provide a degree of confidence that your aXtion Pro case can physically and functionally withstand the relatively infrequent, non-repetitive shocks encountered in various environments.

It is critical that before using your aXtion Pro case with your device, you first perform a waterproof test without your device in the case. It is especially important to ensure the case is properly closed when exposing it to water. An improperly closed case will render it non-waterproof and will damage the device. Do not use your aXtion Pro case with your

device without first ensuring you are readily familiar with your aXtion Pro case and how it functions.

If the aXtion Pro case is damaged or not functioning properly for any reason; immediately stop use. The Joy Factory expressly disclaims all liability and all warranties, whether expressed or implied, for use of an aXtion Pro case that has been damaged for any reason. The case is covered under our one year manufacturing warranty and can be replaced free of charge for any manufacturing defects. If you believe the case has a manufacturing defect, cease use immediately and contact The Joy Factory by email at support@thejoyfactory.com or by telephone at (949) 216-8888, Monday through Friday, 9:00 a.m. to 5:00 p.m., Pacific Standard Time. The Joy Factory will not replace an aXtion Pro case that is damaged, other than one with a manufacturing defect, The Joy Factory is not liable to replace or pay for replacement of your device or any additional items which may be damaged from use of a case with manufacturing defects.

The Joy Factory disclaims all liability for lost aXtion Pro cases and any device stored in a lost case.

Do not use your aXtion Pro case with any other case or bumper. Use of an additional case or bumper will render the aXtion Pro Case non-waterproof, and The Joy Factory disclaims all liability from such use and will void any and all warranties, expressed or implied.

Any alteration to your aXtion Pro case will void any and all warranties and guarantees, whether expressed or implied, and The Joy Factory disclaims any and all liability for damages arising from use of an altered aXtion Pro case.

Using the aXtion Pro case with any other device could lead to an improper seal of the case and will render the case non-waterproof. The Joy Factory disclaims all liability and all warranties, whether expressed or implied, for use of the aXtion Pro case with any other device.

Contact us: support@thejoyfactory.com
 (949) 216-8888
 Monday through Friday,
 9:00 a.m. to 5:00 p.m. (PST)