

INSTRUCTIONS: PUTNAM 16 CHARGING STATION™

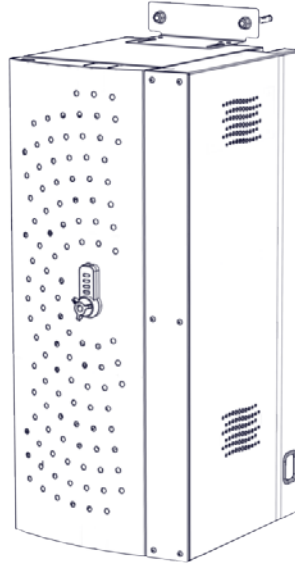

Congratulations on your purchase.

Follow these instructions for easy and fast set-up of your Putnam 16 Charging Station.
For video instructions, go to <https://vimeo.com/216952550>



Warranty:

PC Locs/LocknCharge warrants the product to be free of defects in design, materials, assembly and craftsmanship from the date of purchase to the original retail purchaser. Evidence of original purchase will be required to obtain warranty service.

In the event that a defect, malfunction or failure occurs or is discovered during the warranty period, PC Locs/LocknCharge will repair or replace, at its option, the products which in the reasonable judgment of PC Locs/LocknCharge are deemed defective. All transportation costs shall be borne by the owner and the risk of loss shall be upon the party initiating the transportation.

The warranty does not apply to any product that has been subject to misuse, tampering, neglect, or accident or as a result of unauthorized alterations or repairs to the product. The warranty is in lieu of all warranties expressed or implied, including the implied warranties of merchantability and fitness for a particular purpose which are expressly excluded or disclaimed. In no event will PC Locs/LocknCharge, their directors, officers, employees, or agents be liable for any harm, consequential, incidental, third party, special or indirect damages whatsoever arising out of the use or inability to use the products even if PC Locs/LocknCharge has been advised of the possibility of such damages.

PC Locs/LocknCharge obligation is strictly and exclusively limited to the replacement or repair of any defective products. Some states do not allow the exclusion or limitation of incidental or consequential damages, so the above limitation or exclusion may not apply to you.

Disclaimer:



This information is the intellectual property of IWS Global Pty Ltd and may not be distributed, duplicated or copied in part or full without the written permission. Since the use of this information, the equipment connected and the conditions by which any IWS Global product is used is beyond the control of IWS Global, it is the obligation of the owner and/or user to determine the correct and safe use of any equipment and product. To the extent that the law permits, any liability which may be incurred as a result of the use or future use of a product manufactured or sold by IWS Global is limited to the cost of repairing or replacing the failed product or component at the discretion of IWS Global either within, or outside of warranty periods, and does not extend to any loss or damage which may be caused as a consequence of misuse or failure of the equipment or product or the information contained herein. IWS Global shall not in any event be liable for economic loss of profits, indirect, special, bodily injuries or consequential damages.

Specifications and images are for illustration purposes only. Final product may differ and is subject to change without notice.

PC Locs, LocknCharge and the Padlock device are Trademarks of IWS Global Pty Ltd.

Copyright IWS Global Pty Ltd, January 2017.

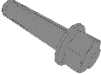

Parts Box for the Putnam 16 Charging Station

Quantity	Item	Image
2	Instructional booklet	
1	Numbered stickers sheet (1 – 16)	
1	3m Extension Power cord <i>(UK version image for illustration only)</i>	
2	Wall Bracket fixings	
1	PIN finder tool	
2	Master Override Keys	
1	Key ring	

Parts Box for the Putnam 16 Charging Station Wall Mount Kit
(Sold separately)

Quantity	Item
1	Wall mount bracket plate
4	Dynabolts
4	Shear nuts
4	Fixing screws

Parts Box for the Putnam 16 Charging Station Wall Mount Kit
(Sold separately)

Quantity	Item
1	Pedestal 
4	Locating Pins (new) 

Wall fixing must be completed to safely use the Putnam 16 Charging Station.
 The Wall Brace Bracket is designed to prevent the Putnam 16 from tipping over.

PLEASE NOTE: The Wall Brace Bracket is NOT designed for hanging/mounting or supporting the weight the unit.
Only suitably qualified persons shall install.

1. Remove the Wall Bracket from the Putnam Charging Station after unpacking.

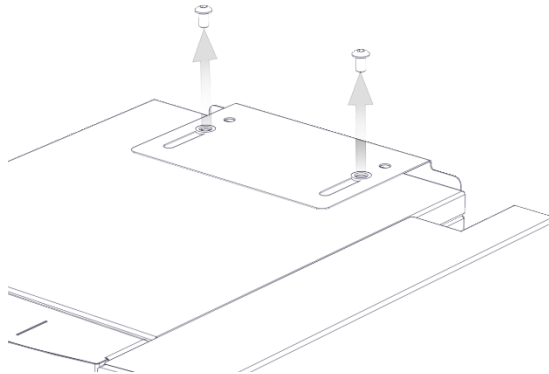

2. Position the Charging Station in your desired location (on a desk or bench against a wall).

3. Position the Wall Bracket and Putnam 16 against the wall

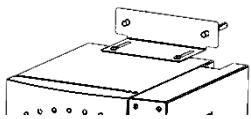

4. Adjust as required

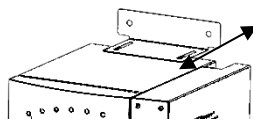

5. Secure the screws to the Putnam 16

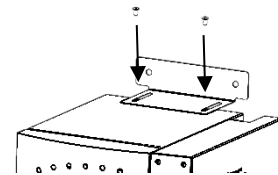

6. Drill holes in wall and insert fixings

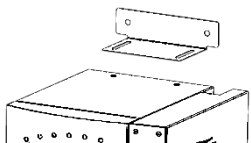

7. Secure with nuts

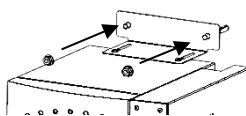

8. Completed installation

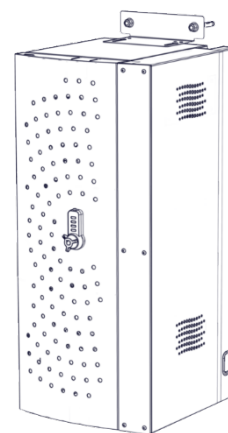

Opening the Putnam 16 Charging Station

Operating the Combination Lock - Combination Lock is set to 0-0-0-0 for shipping.

See section below for setting your own code.

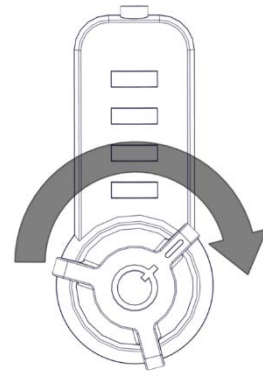
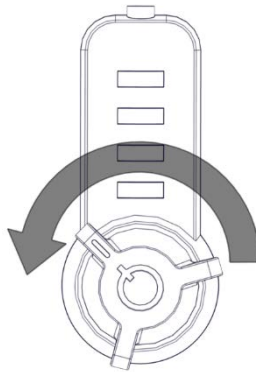
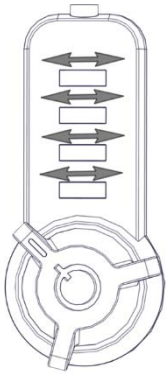

Lock 

Unlock 



Resetting the PIN Code

If you want to change the PIN Code, please follow the steps below.

1. Turn knob to locked position 
2. Turn code wheels to current/correct code
3. Push down and hold the Reset button
4. Rotate the combination wheels to your chosen code. Remember your code.
5. Release the Reset button
6. Turn the knob to unlock 
7. Close the door, turn the knob to lock , and scramble the code wheels

Reset button

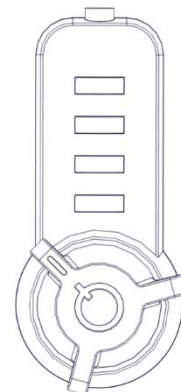

Retrieving lost PIN Code

If you forgot the PIN Code, please follow the steps below to retrieve the PIN Code. Once retrieved, you can then change the code using the guide above.

1. Insert the override key into the key slot and turn knob to unlock position. 
2. Open the door.
3. Remove the internal door cover by unscrewing the Phillips head screws to expose the rear of the lock.
5. Insert the PIN finder needle into a combination-discover hole.
6. Turn the code wheel until it stops. That is the code number for that hole.
7. Repeat for the other 3 holes until you get all numbers.
8. Check that the knob can be locked/unlocked.
9. Note the code, then follow the reset instructions above.

PIN Finder Needle



Combination Discover Holes

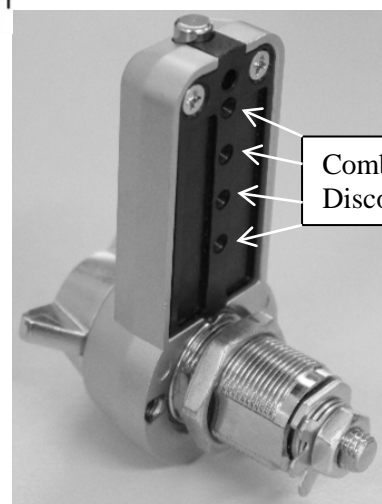

Apply the number stickers

1. Apply the number stickers to shelves matching numbers on the charging panel (1-16; 17-32)

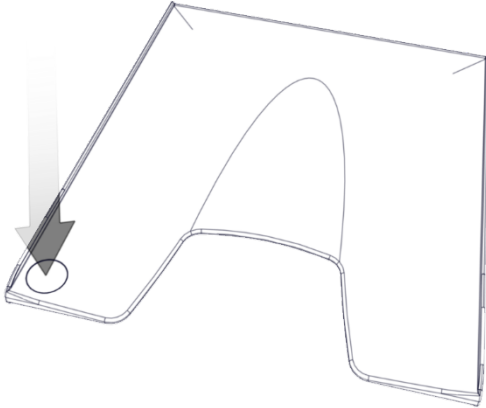

2. The shelf can be removed by lifting gently in the centre and pulling outwards

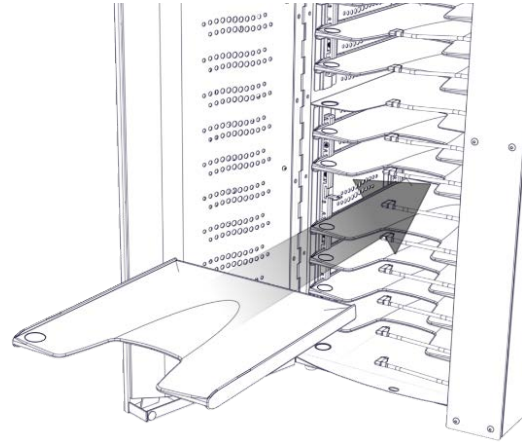

Turning the Putnam 16 Charging Station 'ON'

1. Connect the power cord

2. iPad devices connected will start charging automatically

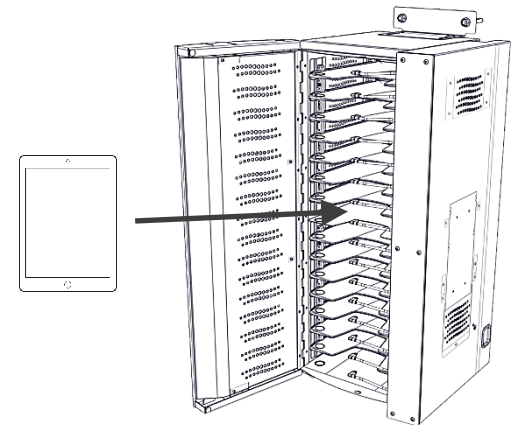
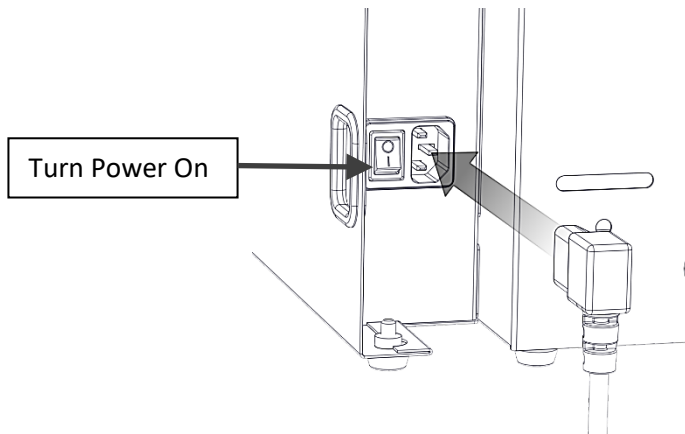

Charging status indicators

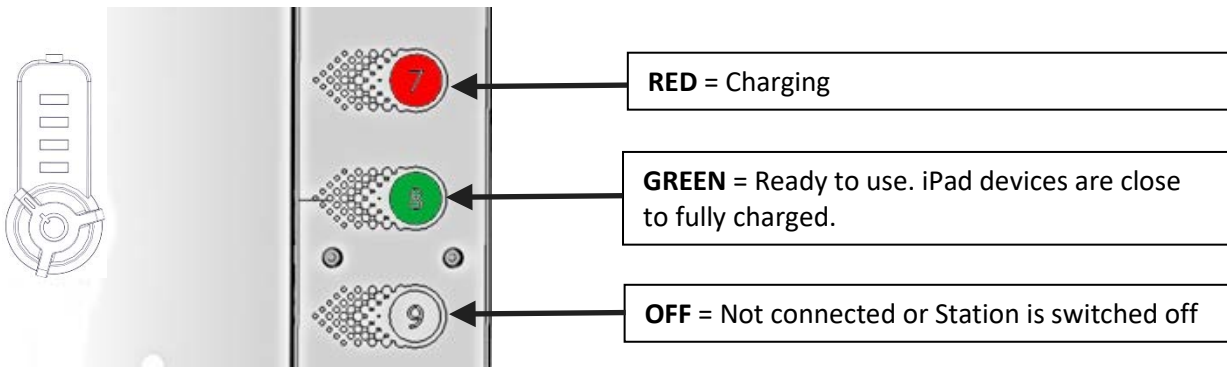

Stacking the Putnam 16 Charging Station with the Putnam Pedestal and a second Putnam 16 Charging Station.
 In order to stack two Putnam 16 Charging Stations together, you must purchase a Putnam Pedestal. The Putnam Pedestal comes with 4 locating pins used for stacking.

Note: Older version of the Putnam 16 Charging Station do not come with the locating pins and aligning holes. The purpose of the locating pins is to help align the units for stacking them on top of one another. If your Pedestal and Charging Stations do not come with pins and locating holes, it is the responsibility of the customer to align the Charging Stations before securing to the wall.

1. Connect the locating pins to the Putnam Pedestal (if applicable)

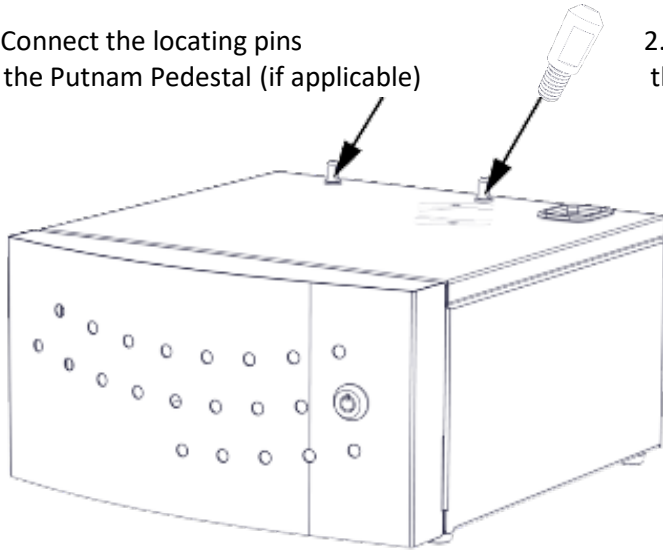

2. Place the first Putnam 16 on the Pedestal aligning to the pins. (or manually align if pins are not applicable)

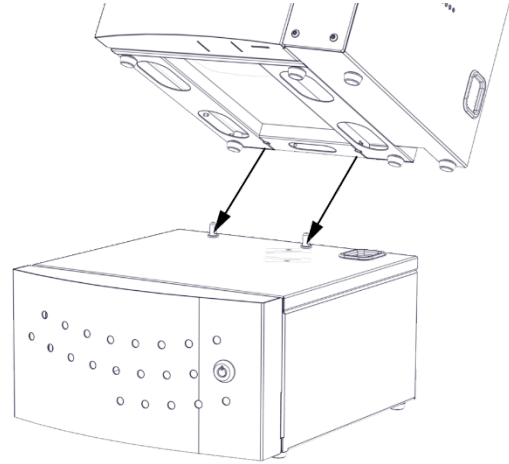

3. Connect the aligning pins to the first Putnam 16 (if applicable)

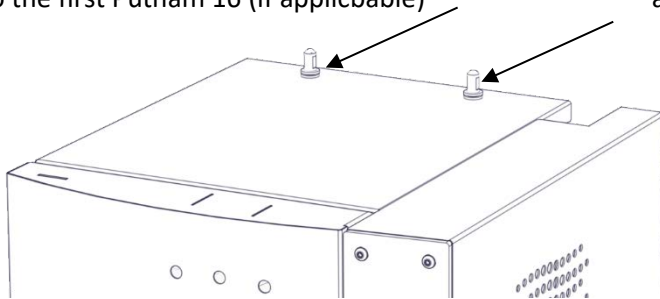

4. Place the second Putnam 16 on the first Putnam 16 aligning to the pins. (or manually align if pins are not applicable)

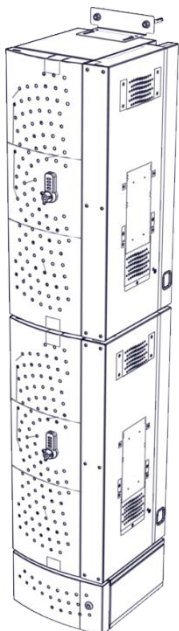
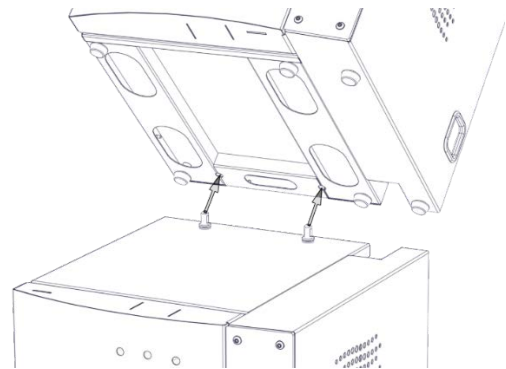

5. Complete the Putnam Stack (Pedestal and two Putnam 16 Charging Stations) by attaching the wall bracket to the Putnam Stack.
 Refer to the previous section on how to fix the Putnam Stack to the wall.

6. Connect the Pedestal cables to the Putnam Cabinet(s). Turn the power ON.

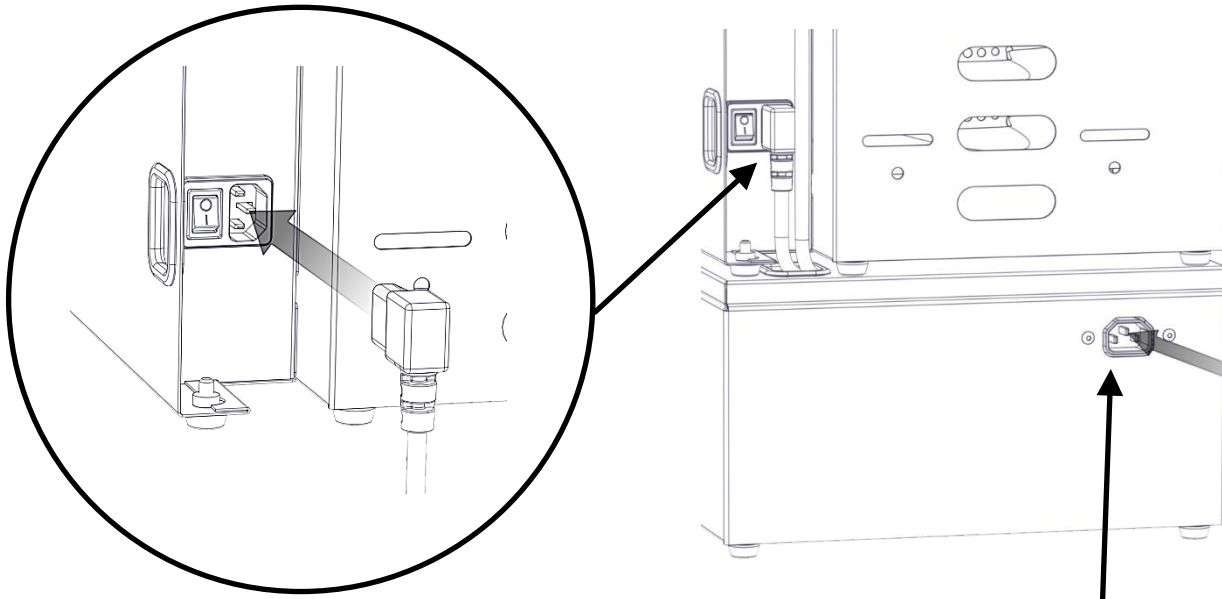

Use Putnam 16 Charging Station Power Cord to connect the whole 'Tower' to power.

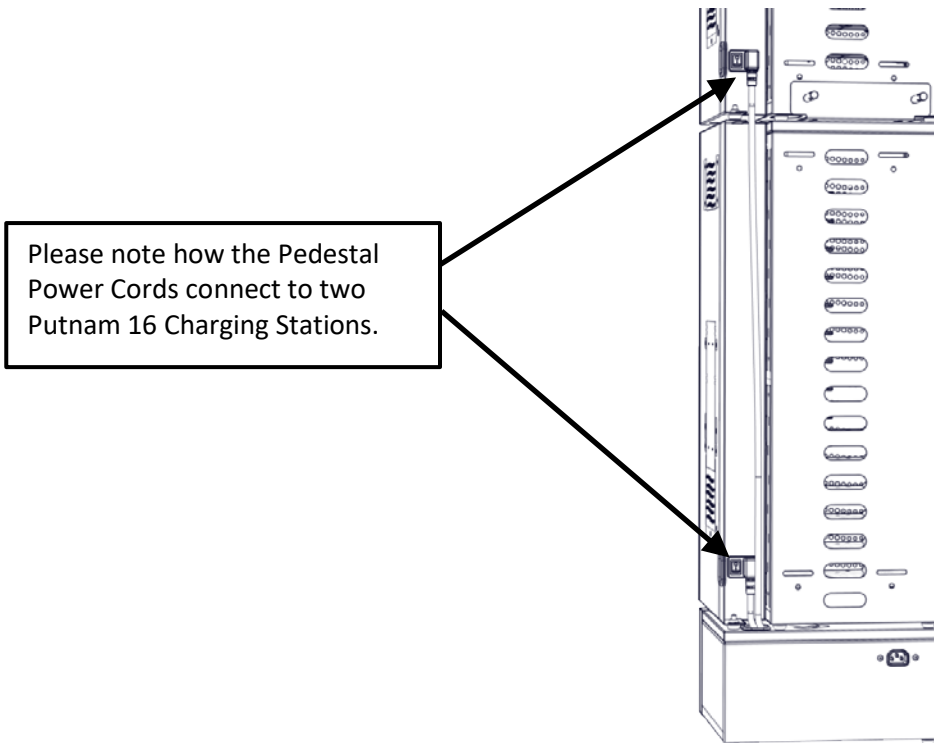

Changing iPad cables

1. Undo screws

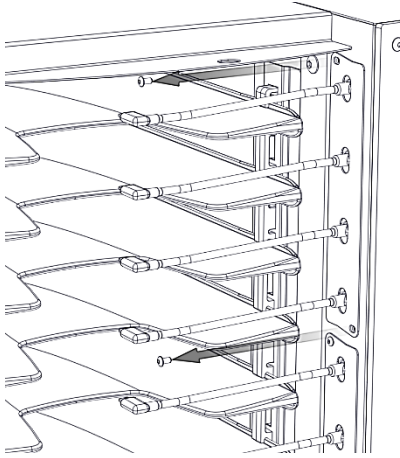

2. Remove retaining plate

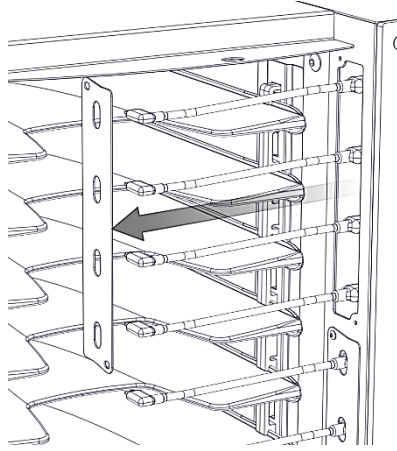

3. Replace cable(s) & replace plate

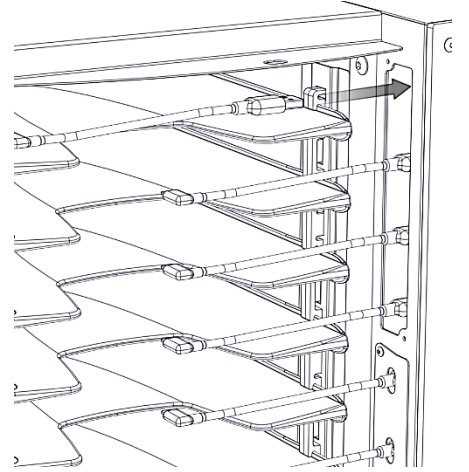

Installing the Wall Mount Bracket

The wall mounting kit can be purchased separately.

1. Place the bracket in the desired location. Ensure it is level and then mark holes.

2. Drill holes in the marked in the marked areas. Use a A 10mm masonry drill

3. Insert Dynabolts

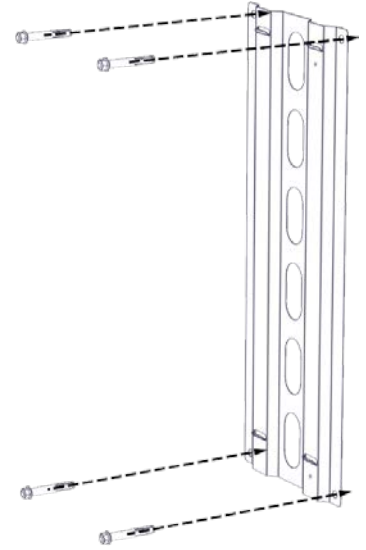
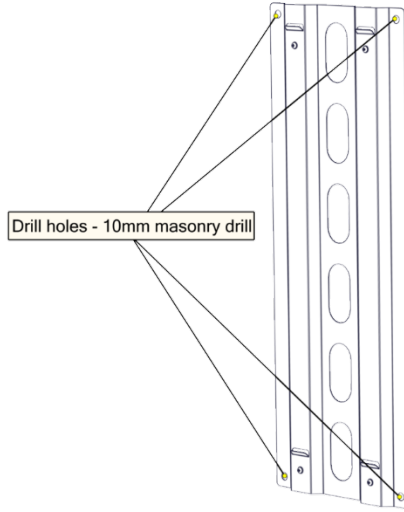
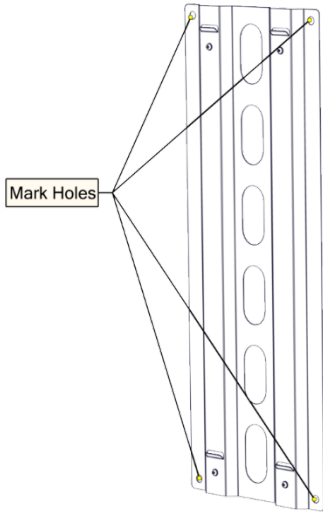

4. Remove the hex nuts

5. Install the shear nuts and tighten until the nut shears off

6. Remove the top and bottom plastic shelves

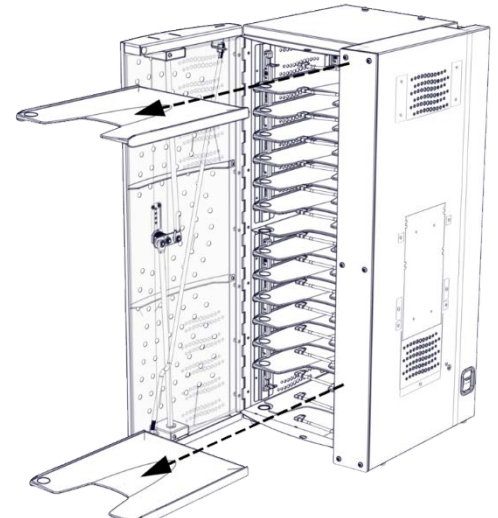
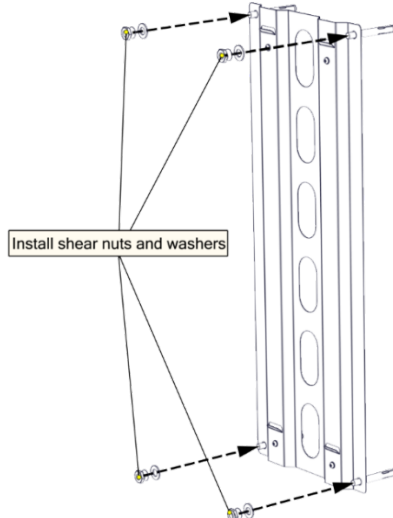
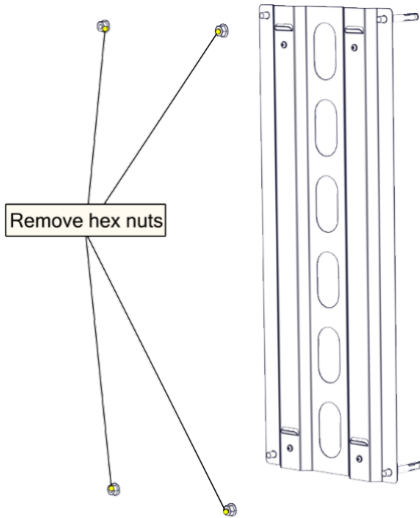

7. Hang the Putnam 16 on the bracket hooks

8. Insert 4 securing screws and replace the plastic shelves

